

MEASURING AND CONTROL STATIONS FOR AIR VOLUME AND PRESSURE

A TYPE



*"Air-Trac®" system***Measuring and control stations**

The basic functions of air flow control such as: constant air volume, static pressure, supply/return balancing etc. are very simple and straightforward in theory. However the practical application of these functions, is very difficult due to the small magnitudes of the measuring signals (velocity pressure in most cases).

Most air flow control applications involve 4 stages of control process:

- Sensing the air flow based on a pressure differential signal (velocity pressure produced by the Flo-Cross® air flow sensor).
- Transducing and amplifying the signal into a format used by the controller (analogue, pneumatic, DDC, etc.).
- Converting the signal into a proper control relationship by use of a square root extractor to make the control signal linear to air volume.
- Analysing the control signal and if necessary adjusting (resetting) the air flow.

The overall accuracy of the control system (loop) is totally dependent on the intrinsic accuracy of each of these components and a small error in the first step will be amplified by the second and so on.

Because a controller can control no better than the signal it receives, Barcol-Air developed the Flo-Cross® air flow sensor, which provides a highly accurate test signal, averaged over at least 24 test points and amplified by at least 2,5 times the velocity pressure. This sensor has a proven accuracy of 2,5% even with irregular duct approach.

This accurate signal can be read manually through a pressure-gauge or can be relayed to any building management system to be used to control such functions as: energy management, balancing supply and return air volumes, monitoring and controlling minimum fresh air volumes, tenancy billing by floor or by zone, to provide a reliable accurate reference point for air flow commissioning in VAV systems, etc.

The Barcol-Air measuring and control station system consist of 3 different standard devices:

- Type AE..... for air flow measuring.
- Type AF..... for air flow measuring and air flow control.
- Type AH..... for air flow measuring and system pressure control.

Application example:

The design of your air system is now finished. All duct sizing, air flows and pressure drops have been calculated and the duct work drawings are (almost) finalised. The design is usually based on several safety factors and mean standards of operation. This means that the system may well consume more energy or produce more noise than necessary when installed. Now is the time to look at the plans and introduce a method to ensure that the system can be fully optimised during commissioning at site. By installing Barcol-Air measuring and control stations you can confidently control the system at site to the most energy efficient operating levels.

The "Air-Trac®" system

Constant volume systems can be optimised by one time commissioning of manual operated dampers. However, today from an energy point of view, constant volume systems are no longer used in air conditioned buildings. Variable Air Volume or Induction VAV systems in combination with modern Building Management Systems comply with todays energy saving requirements. In order to maximise energy savings under all load conditions it is necessary to monitor and control air flow and pressure during operation. Unfortunately nobody can afford having commissioning engineers working in the building 24 hours a day throughout the buildings life. That is why Barcol-Air developed the "Air-Trac®" system that monitors, controls and communicates the air flow through the complete duct system 24/7.

Summary

- Complies with todays energy saving requirements according to green building accessors like LEED, BREEAM, ESTIDAMA etc. Continuously monitoring and controlling air flow and system pressure to minimise energy consumption 24 hours a day throughout the buildings life.
- Flo-Cross®, high accuracy, averaging air flow measuring velocity sensor with 100% repeatability on site measurements.
- Suitable for use with pneumatic, analogue electronic or DDC transmitters/controllers.

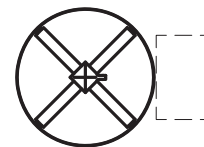

*Circular air flow measuring station
Type AEP....*

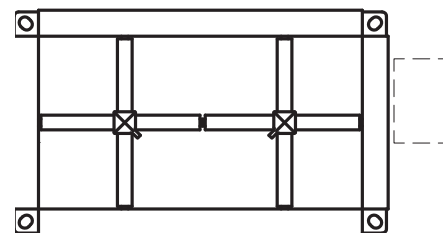

*Rectangular air flow measuring station
Type AER....*

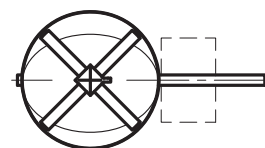

*Circular air flow measuring and air flow
control station
Type AFQ....*

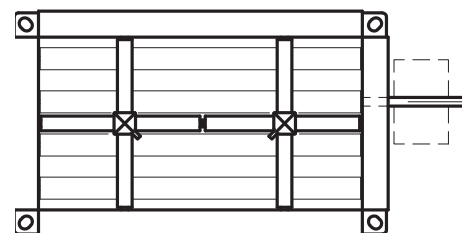

*Rectangular air flow measuring and air
flow control station
Type AFS...*

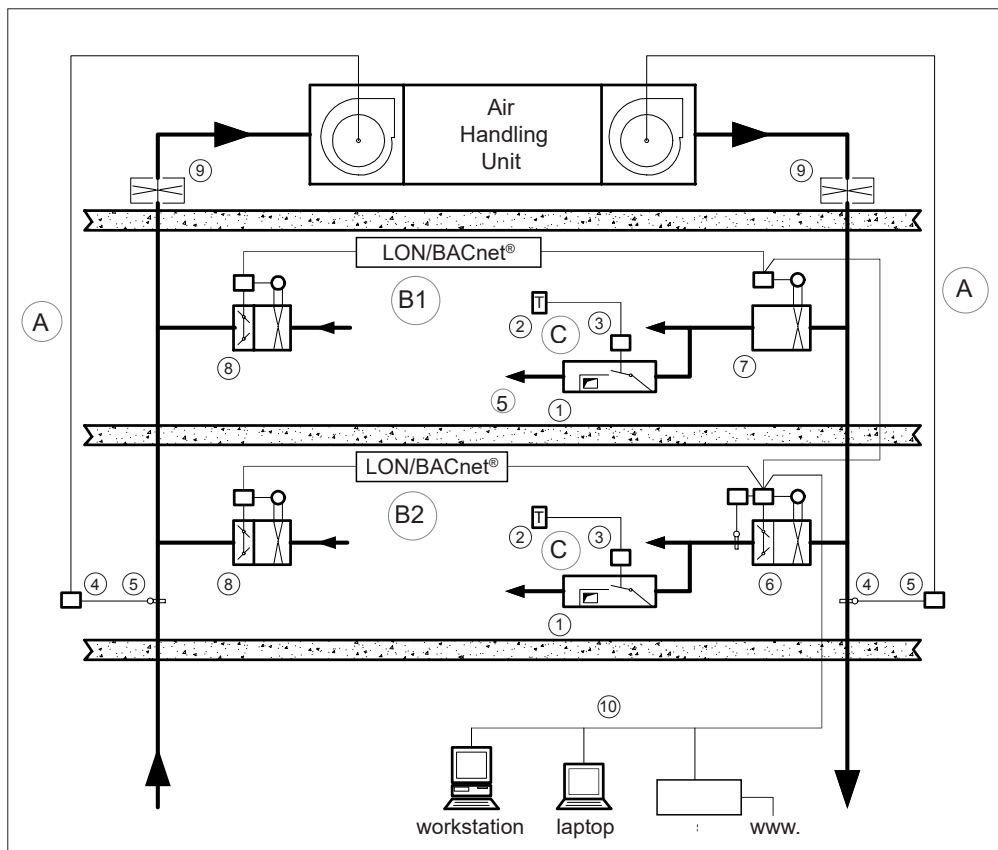

Reference list:

1. VAV terminal with or without Induction:
without induction: type NA, NB, NK, NL, NS
with induction: NV
2. Room thermostat
3. VAV controller (LON/BACnet®)
4. Duct static pressure sensor
5. Speed controller (BMS) for air handling terminal with inputs for
- System pressure
- Air volume
6. Air flow measuring and pressure control station type AHQ / AHS
7. Air flow measuring station type AEP / AER
8. Air flow measuring and control station type AFQ / AFS
9. Air flow measuring station type AEP / AER
10. Building Management System (BMS)

Control description

This type of control is used to prevent air flowing from one room to another. The reason for this can be that the air in one of the rooms is polluted or too hot or too cold. The pressure in both rooms can be controlled by a difference between supply and return air. Positive (over) pressure is created when the supply air volume is more than the return or exhaust air volume. Negative (under) pressure is created when more air is exhausted than supplied.

The "Air-Trac®" system combines these loops to give maximum energy savings under all load conditions.

A. Speed control of central AHU

The supply fan is controlled to keep the required pressure in the riser(s) to a minimum value but still allowing the system to maintain the design room conditions. The extract fan can be controlled by equalising supply and extract air flows to give the required under / over pressure in the building.

B. "Air-Trac®", supply and return air balancing, with or without pressure control.

B1. without pressure control:

The supply air flow is constantly measured and the extract air flow is matched or controlled to give the required under/over pressure per floor or zone.

B2. with pressure control:

The supply duct pressure is controlled to the minimum value that still allows the VAV terminals in this zone to maintain the design room conditions.

C. Room temperature control:

A VAV terminal controls the air volume to the room, depending on the cooling or heating load required thus saving energy consumption.

Example: Room pressure control for laboratory with fume-cupboard

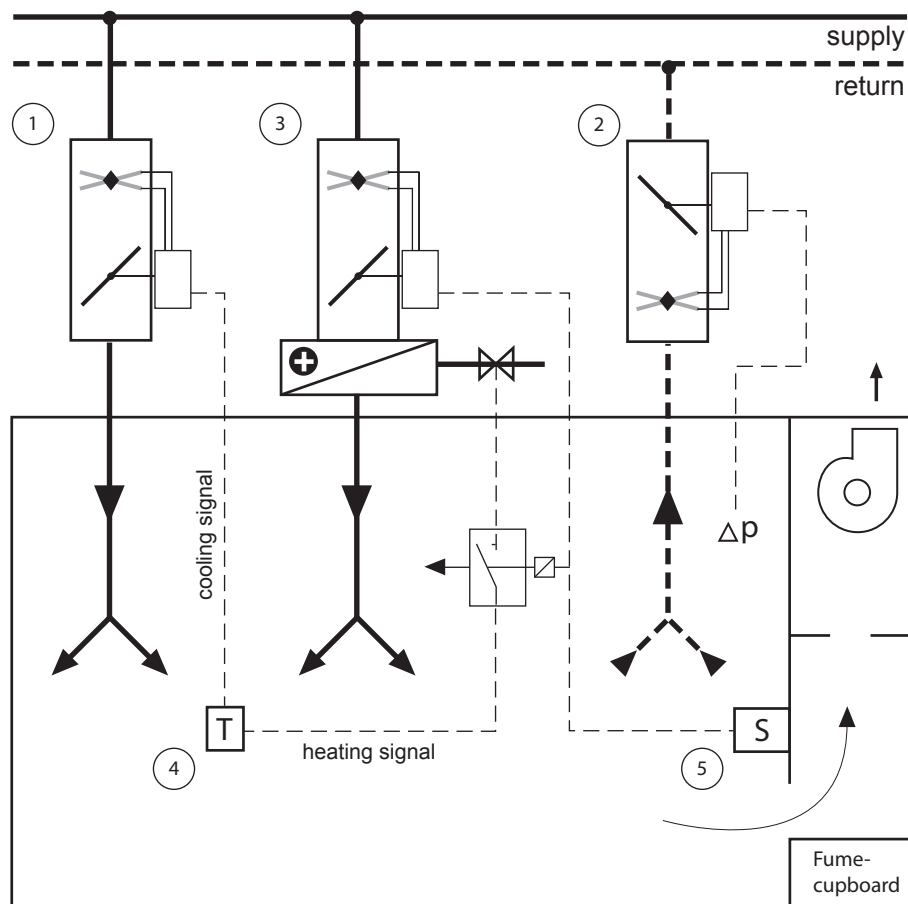

Reference list:

1. VAV terminal for room temperature control:
 rectangular: Type NK, NL or NS
 circular: Type NA or NB
2. Pressure control station with air flow measuring sensor:
 rectangular: Type AHS
 circular: Type AHQ
3. VAV terminal with integral reheat coil for room temperature control:
 rectangular: Type NK, NL or NS
 circular: Type NA or NB
4. Room thermostat or room temperature sensor
5. Fan speed switch for fume-cupboard

Control description

Under normal conditions (fume-cupboard switched off), the room temperature is controlled by the VAV controller (1) and room pressure is kept at the required value with pressure control station (2).

When the fume-cupboard is switched on, the supply air must be raised or exhaust air must be lowered, in order to keep the room pressure at the required value. When the air flow, extracted by the fume-cupboard, is too high to be compensated by the pressure controller (2) an additional VAV terminal (3) is necessary to compensate the high extract air volume.

To prevent under cooling the room/laboratory with the high (primary) supply air volume the additional VAV controller can be equipped with a reheat coil.

Example: “Master-Slave” room pressure control

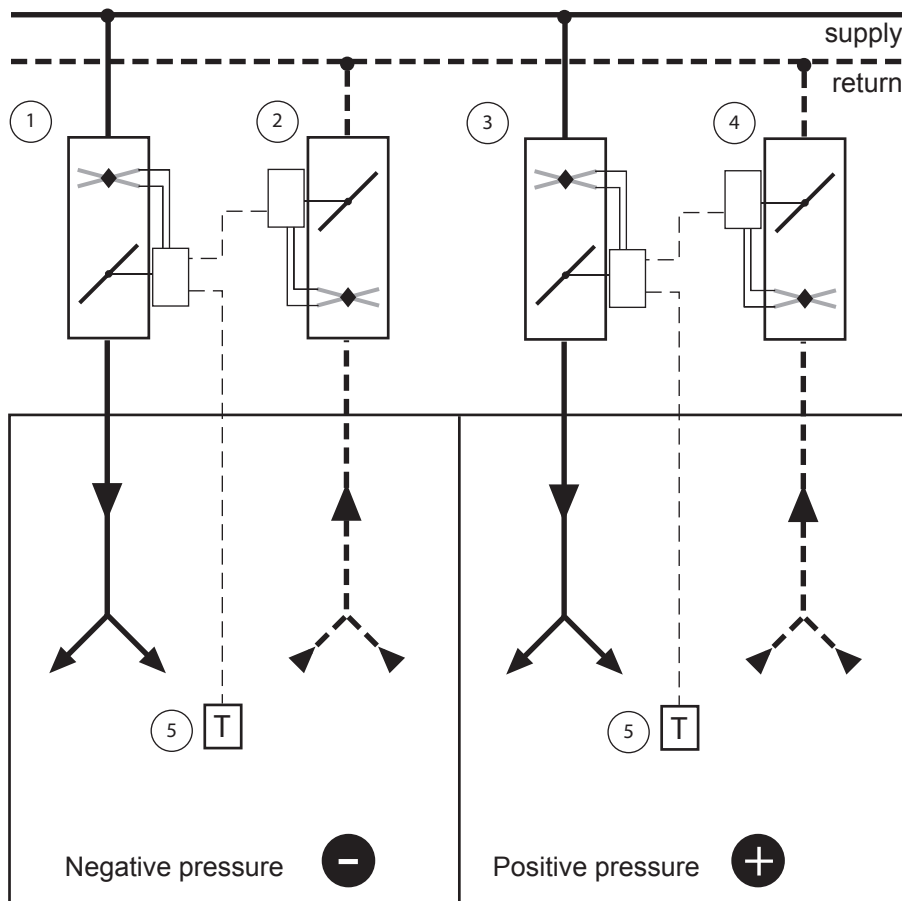

Reference list:

1. Supply air VAV terminal (master) for room temperature control
 rectangular: Type NK or NL
 circular: Type NA or NB
2. Return air VAV terminal (slave) for room (under) pressure control
 rectangular: Type NK or NL
 circular: Type NA or NB
3. Supply air VAV terminal (master) for room temperature control
 rectangular: Type NK or NL
 circular: Type NA or NB
4. Return air VAV terminal (slave) for room (over) pressure control
 rectangular: Type NK or NL
 circular: Type NA or NB
5. Room thermostat or room temperature sensor

Control description

This type of control is used to prevent air flowing from one room to another. The reason for this can be that the air in one of the rooms is polluted or too hot or too cold.

The pressure in both rooms can be controlled by a difference between supply and return air. Positive (over) pressure is created when the supply air volume is more than the return or exhaust air volume. Negative (under) pressure is created when more air is exhausted than supplied.

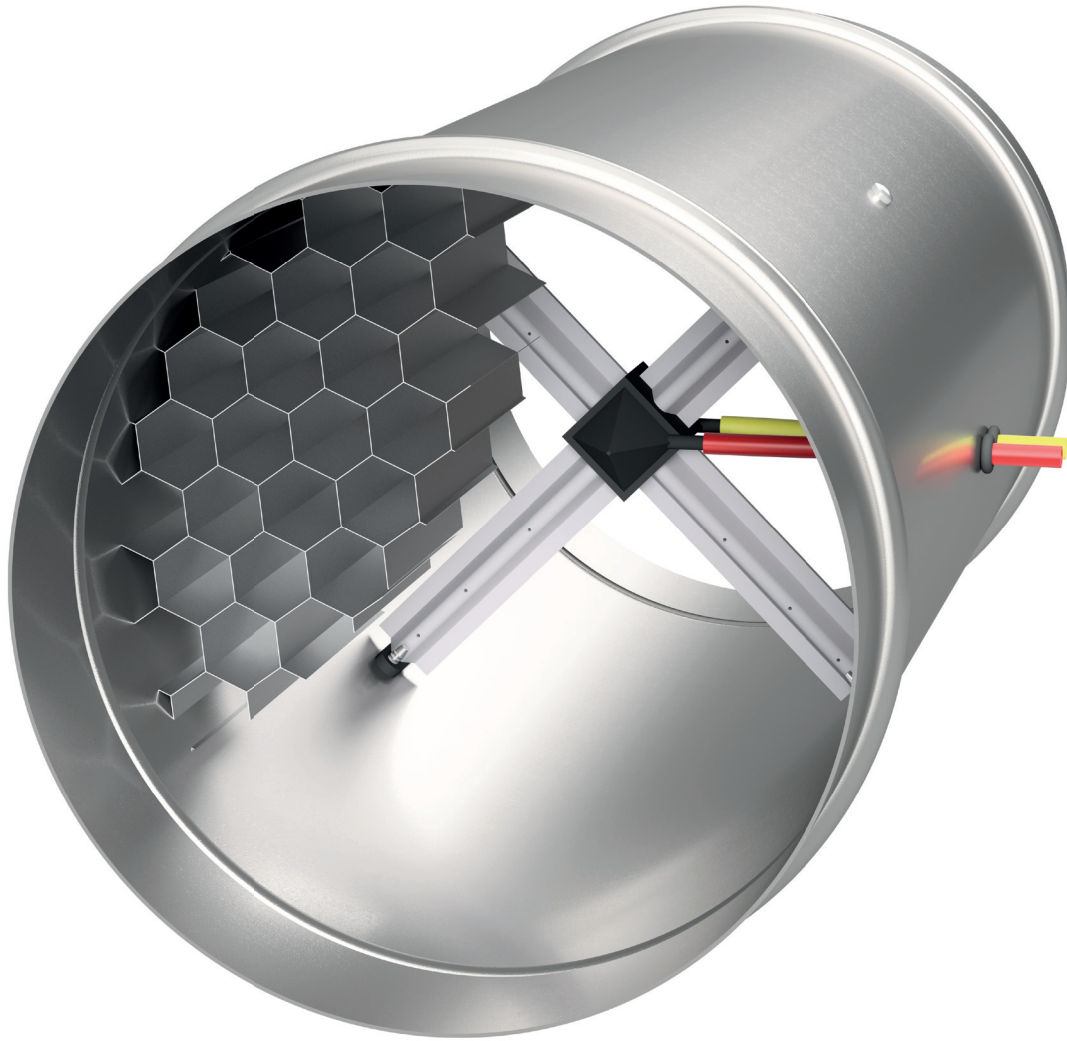

Type AEPGOOB

Composition type designation:

A - E - P - O - O - O - B

Ordering example:

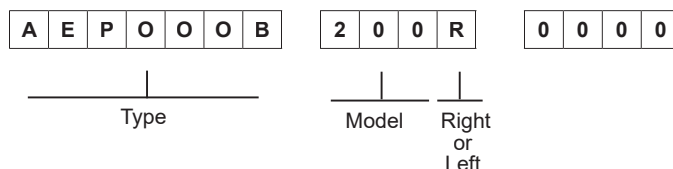

A Position 1: **Product Group**

A = accessoires

E Position 2: **Function**

O = not applicable
 E = air volume measuring station
 F = air volume measuring and control station
 H = air volume measuring and pressure control station
 1 = non standard, specify separately

P Position 3: **Controls (manufacturer)**

O = not applicable
 P = circular air volume measuring station
 Q = circular measuring and control station
 1 = non standard, specify separately

O Position 4: **Outlet**

O = not applicable
 D = double wall
 G = honeycomb air straightener
 F = double wall and honeycomb air straightener (price on request)
 1 = non standard, specify separately

O Position 5: **Controls (manufacturer)**

O = not applicable

O Position 6: **Controls (type & function)**

O = without controls
 For controls, contact our sales staff

B Position 7: **Sensor**

O = not applicable
 B = Flo-Cross® 2 x 12 point averaging and signal amplifying air flow sensor (standard)
 D = Flo-Cross® and static pressure sensor
 1 = non standard, specify separately

Ordering information:

Standard terminals:

- quantity of terminals
- complete 7 digit code
- terminal size or model
- air volume setting (Vmax, Vmin etc)
- control handing (standard right side)
- installed length (type AEPOOOB)
- supply or return air

Non standard terminals:

- for non standard terminals a full description and/or drawing are requested

Type AEP...B / AFQ...B / AHQ...B

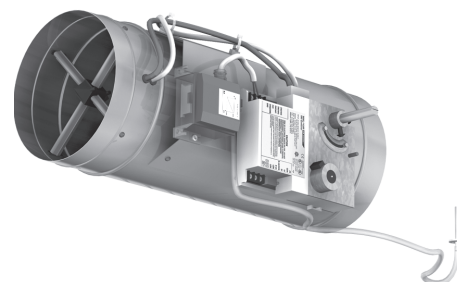
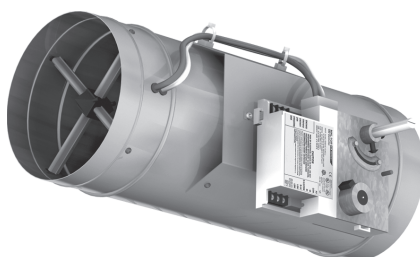

Application

The type AEP...B circular air flow measuring station is designed for the accurate measurement of air flow in air duct systems courtesy of the patented air flow sensor type Flo-Cross®. This accurate signal can be read manually through a pressure-gauge or can be relayed to any Building Management System to be used to control such functions as: energy management, balancing supply and return air volumes, monitoring and controlling minimum fresh air volumes, tenancy billing by floor or by zone, to provide a reliable accurate reference point for air flow commissioning in VAV systems, etc.

The type AFQ...B circular air flow measuring and air flow control station not only measures (like type AEP...B), it also controls the air flow in air duct systems. These stations are designed to be used for optimum floor/zone balancing purposes by controlling return air flow in accordance to a measured supply air flow.

The type AHQ...D circular air flow measuring and pressure control station is designed to control the supply duct pressure per zone, to a minimum value that still allows the VAV terminals in this zone to function efficiently, reducing operating cost and noise level.

Features for type AEP, AFQ and AHQ:

- Flo-Cross®, high accuracy, centre-averaging air flow sensor.
- Static measuring device with 100% repeatability on-site measurements.
- Amplified signal, at least 2,5 times, to improve reading accuracy at low air velocity.
- The large number of test points (at least 24) ensures a true average measurement signal.
- Better than 2,5% accuracy even with irregular duct approach.
- Required minimum straight ductwork approach of 1x diameter only.
- Compact design.
- Suitable for large air volumes.
- Low pressure loss over the terminal.
- Low noise production.
- Maintenance free.

Technical information

Casing:

- Single wall, air-tight construction made of galvanized sheet steel (non spiral); casing leakage rate to Class II VDI 3803 / DIN 24 194. Duct-sleeve connections at the in- and outlet are suitable for DIN 24 145 or DIN 24 146 connections.
- With turbulent oncoming air flow an air straightener type A..G... is recommended (free area 98%, aluminium construction).

Flo-Cross®:

- Extruded aluminium construction with nylon core + feet.
- Twin test tubes: polyurethane flexible tubes, internal $\varnothing 4$ mm external $\varnothing 6$ mm, red high pressure, yellow low pressure.

Damper (applicable for control stations type AFQ and AHQ):

- Damper blade: made of steel, sandwich construction of twin blade and neoprene gasket (low leakage).
- Damper shaft: aluminium, $\varnothing 12$ mm with self lubricating Nylon bearings.

Static pressure sensor (applicable for control station type AHQ):

- Aluminium construction complete with mounting bracket, to be fitted by others in the duct system.

Controls:

Suitable for use with pneumatic, analogue electronic or DDC controllers. Controls can be factory fitted, wired and calibrated. Controls enclosure (galvanized sheet steel) can be provided optionally.

Delivery format

Delivery format:

- Controls location are as a standard fitted on the right hand side of the terminal when looking in the direction of the air flow.
- On request, the terminal can be delivered with connections on the left hand side.
- When terminals are ordered with controls, these will be factory fitted, wired and calibrated.
- When terminals are ordered with 'free-issue' controls by others, wiring diagrams and mounting instructions must be provided.

Type AEP...B / AFQ...B / AHQ...B

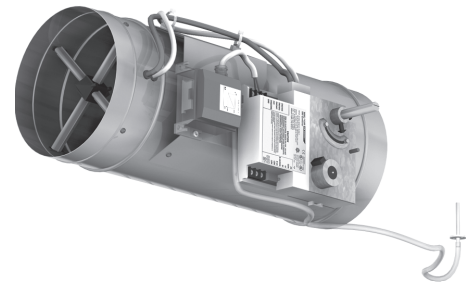
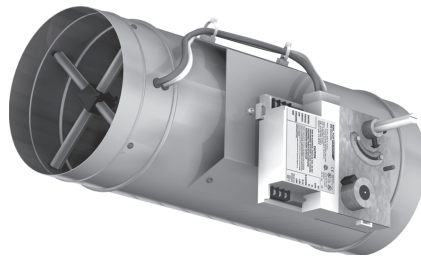

Specify as:

Example:

Supply and install circular air flow measuring and pressure control stations constructed from galvanized sheet steel. The casing leakage rate shall be classified according to class II, VDI 3803/DIN 24 194 and the duct-sleeve connections shall be suitable for DIN 24 145 or DIN 24 146 respectively. The measuring and control station shall have low leakage, sandwich construction and oval shaped damper blade with neoprene gasket and an aluminium damper shaft with self lubricating Nylon bearings. A centre averaging air flow sensor with at least 2 x 12 test points and amplified signal air flow sensor, type Flo-Cross® shall control the air flow with an accuracy not less than 2.5 %.

The controller shall be I/A Series, DDC controller:
LonMark® compatible, type MNL-V2RVx or
BACnet® compatible, type MNB-V2 (1 for air flow measuring and 1 for pressure control).

Controls must be factory fitted, wired and calibrated according to the following requirements.

- Minimum air volume 60 l/s.
- Maximum air volume 250 l/s
- Static pressure setting 100 Pa.
- Terminal size 200 mm.
- Max. pressure loss 38 Pa.
- Max. discharge sound index < NC20 (@250Pa Δp).
- Max. radiated sound index < NC20 (@250Pa Δp).

Ordering example :
type – model – handing =
AHSOOD – 200R

Manufacturer: Barcol-Air, the Netherlands

Installation instructions:

The Barcol-Air VAV terminals shall be installed using at least two circular support brackets, with anti-vibration rubber under the terminal. Each of these bracket(installations clamps) shall be fixed with two threaded rods to the ceiling slab above.

This installation method:

- 1 Shall prevent the body of the VAV terminal from high mechanical tension, which could damage the construction and performance of the terminal.
- 2 Shall prevent torsion on the VAV terminals, which could cause malfunction of the damper blades.
- 3 Provides some flexibility to the final location of the VAV terminals.
- 4 Use at least 1x diagonal straight duct length before the VAV inlet.

- 5 Additional manual volume control dampers (VDC's) before the inlet are not required / recommended!!
6. All connections shall be thermally isolated.
7. Pressure sensing tubes of Flo-Cross® air flow sensor shall not be "kinked" or otherwise obstructed by the external duct insulation.

Installation of circular VAV terminals can be done in a similar way, with the only assumption that two circular support brackets with anti-vibration rubber (installation clamps) instead of DIN-rail or L-profile shall be used. To prevent the VAV terminal from rotation, we recommend to use a complete clamp (support + top bracket), so that the terminal is 'clammed' in between.

Optional 4 x Mupro fixing hooks can be used (see drawing).

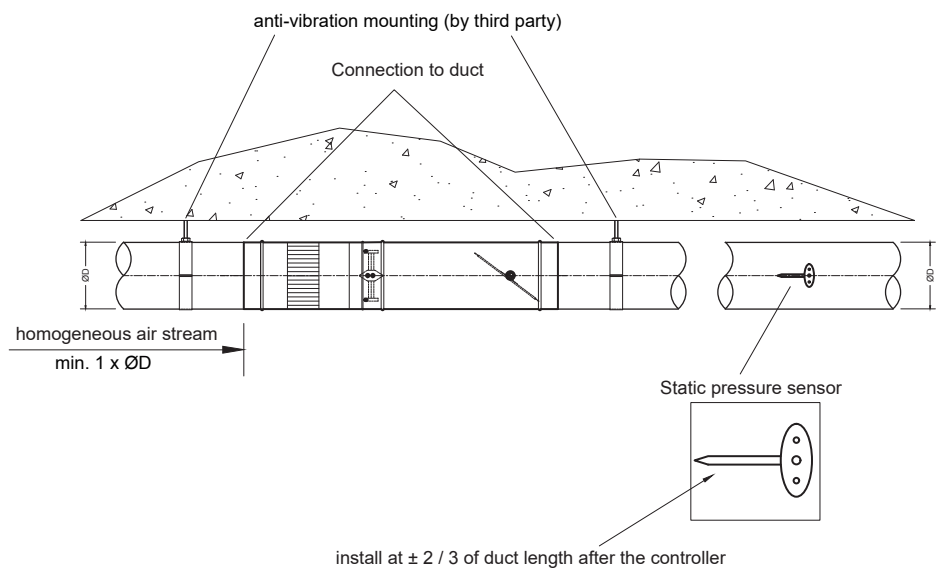

Mounting drawing type AHQ...B

Type AEP...B / AFQ...B / AHQ...B

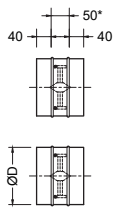
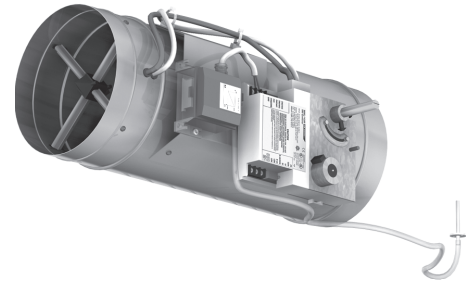
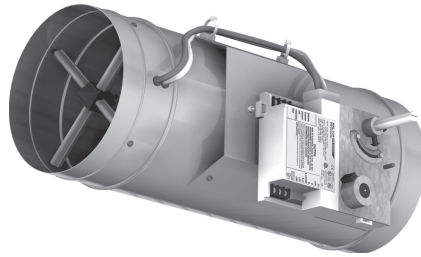

Type AEPOOBB

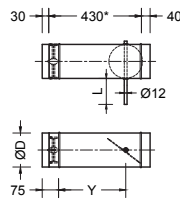

Type AFQOOBB

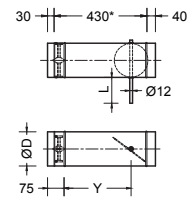

Type AHQOOBB

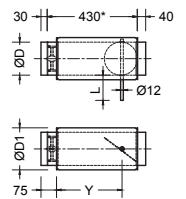

Type AHQDOBB

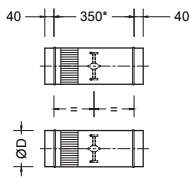

Type AEPGOBB

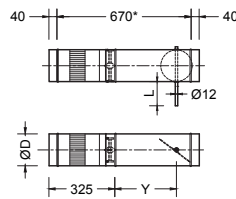

Type AFQGOBB

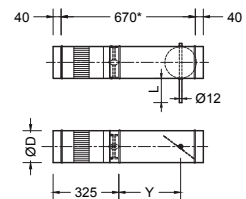

Type AHQGOBB

Dimensions

Model	100	125	160	200	250	315	355	400
ØD	98	123	158	198	248	313	353	398
ØD1	150	180	200	250	300	355	400	450
Y	310	310	310	300	285	260	245	235
L	95	95	95	95	95	95	95	105

Notes:

1. All dimensions are in mm.
2. Diameters from 500 to 900 mm available upon request.
3. * = Installed length.
4. Dimensions on double wall type available upon request.

Type AEP...B / AEPG...B

Flow curves, air flow versus Δp

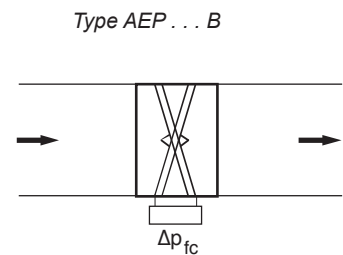
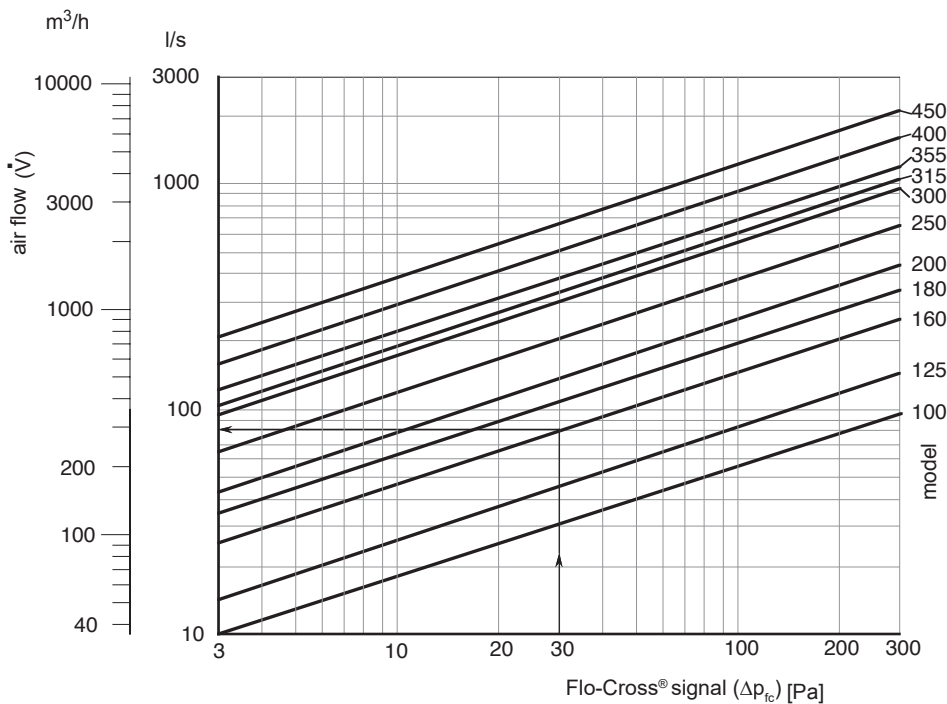

Kv values

Model	100	125	160	180	200	250	300	315	355	400	450
Kv [l/s / 1Pa]	5.5	8.5	15.0	20.0	24.9	35.4	54.1	58.9	74.3	92.6	122.3

Interpolation not allowed.

Example

To be determined the air flow for a terminal size 160 with a pressure differential signal (Δp_{fc}) of 30 Pa. There are two ways to determine the air flow:

Method-1, with use of the selection graph.

Reading off the flow, at $\Delta p_{fc} = 30$ Pa and terminal size = 160, the result is 82 l/s

Method-2, arithmetical determination.

The given Kv value (15.0) must be used in the following formula:

$$V = Kv \sqrt{\Delta p_{fc}} = 15.0 \times \sqrt{30} = 82 \text{ l/s}$$

Zeta values

Example

Model	100	125	160	180	200	250	300	315	355	400	450
Zeta	0.45	0.73	0.46	0.39	0.38	0.49	0.46	0.46	0.55	0.561	0.61

To be determined the static pressure loss for an terminal size 160 and a velocity of 8 m/s.

The given Zeta value (0.46) must be used in the following formula:

$$p_s = Zeta \times 0.5 \times \rho \times v^2 = 0.46 \times 0.5 \times 1.2 \times 8^2 = 18 \text{ Pa}$$

* ρ = Specific density ($\approx 1.2 \text{ kg/m}^3$ at 20°C and 50% rel. humidity)

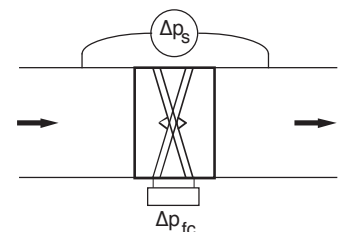

Sound data

Type AFQ(G)OOB
AHQ(G)OOB

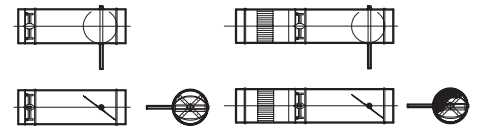

Sound data $\Delta p = 125$

Model	data referring to inlet spigot				min. Δp_s	$\Delta p = 125$ Pa																	
						discharge sound						radiated sound single wall											
	velocity		air volume			L_w in dB/Oct. (re 1pW)						Lp values			L_w in dB/Oct. (re 1pW)						Lp values		
						125 Hz	250 Hz	500 Hz	1000 Hz	2000 Hz	4000 Hz	dB(A)	NC	NR	125 Hz	250 Hz	500 Hz	1000 Hz	2000 Hz	4000 Hz	dB(A)	NC	NR
	m/s	l/s	CFM	m ³ /h		Pa	dB								dB								
100	2	15	31	53	2	43	44	40	38	34	22	--	--	--	19	--	19	20	23	21	--	--	--
	4	29	62	106	8	49	50	46	44	40	29	24	--	20	26	23	26	27	30	28	--	--	--
	6	44	94	160	17	53	54	51	48	44	34	28	22	24	30	27	30	31	34	32	--	--	--
	8	59	125	213	30	57	58	54	52	49	39	31	26	28	33	30	33	34	37	35	--	--	--
10	74	156	266	47	59	61	58	55	52	43	34	29	31	35	32	35	36	39	37	--	--	--	
125	2	23	49	84	2	40	43	40	39	34	25	--	--	--	28	24	25	22	23	17	--	--	--
	4	47	99	168	7	47	49	46	45	40	31	23	--	--	35	31	32	29	30	24	--	--	--
	6	70	149	253	16	52	54	51	49	44	36	27	21	24	39	35	36	33	34	28	--	--	--
	8	94	198	337	28	56	58	55	53	48	40	31	25	28	42	38	38	35	37	31	21	--	--
10	117	248	421	44	59	61	58	56	51	44	34	29	31	44	40	41	38	39	33	23	--	--	
160	2	39	82	139	2	39	41	40	38	37	32	--	--	--	28	24	25	22	23	18	--	--	--
	4	78	164	279	7	47	48	46	44	41	36	22	--	--	35	31	32	29	30	25	--	--	--
	6	116	246	418	15	52	52	50	49	44	39	26	--	22	39	35	36	33	34	29	--	--	--
	8	155	328	558	26	56	56	54	52	48	42	30	24	26	42	38	38	35	37	31	21	--	--
10	194	410	697	41	60	60	58	56	51	45	34	28	30	44	40	41	38	39	34	23	--	--	
200	2	61	129	219	2	39	34	37	34	30	23	--	--	--	29	24	24	23	23	18	--	--	--
	4	122	258	439	6	48	44	46	42	37	31	20	--	--	36	31	31	29	30	25	--	--	--
	6	183	387	658	14	54	51	52	47	42	36	26	--	20	40	35	35	33	34	29	--	--	--
	8	244	516	878	25	58	55	56	51	46	40	31	23	25	43	38	38	36	37	31	21	--	--
10	305	645	1097	39	61	59	60	54	50	43	34	27	30	45	40	40	38	39	34	23	--	--	
250	2	96	203	345	1	41	43	42	39	34	30	--	--	--	29	24	24	23	23	18	--	--	--
	4	192	406	690	6	50	51	50	45	40	35	25	--	20	36	31	31	29	30	25	--	--	--
	6	288	609	1035	13	56	56	55	50	44	39	30	23	26	40	35	35	33	34	29	--	--	--
	8	383	812	1380	23	60	60	59	53	47	43	34	28	30	43	38	38	36	37	31	21	--	--
10	479	1015	1725	36	63	63	62	56	50	45	37	32	34	45	40	40	38	39	34	23	--	--	
315	2	153	324	550	1	42	45	41	41	38	33	--	--	--	30	24	24	23	23	19	--	--	--
	4	306	648	1101	5	52	52	48	47	43	38	26	--	21	37	31	31	30	30	26	--	--	--
	6	459	971	1651	12	58	57	54	52	48	42	31	24	27	41	35	35	34	34	30	--	--	--
	8	612	1295	2202	22	63	61	58	56	52	46	35	29	31	44	38	38	36	37	32	21	--	--
10	764	1619	2752	34	67	64	62	59	55	50	39	34	35	46	40	40	39	39	35	23	--	--	
355	2	195	412	701	1	42	52	45	45	40	38	24	--	21	30	24	24	23	23	19	--	--	--
	4	389	824	1401	5	53	56	51	50	43	42	29	24	26	37	31	31	30	30	26	--	--	--
	6	584	1236	2102	12	59	60	56	54	46	45	33	28	30	41	35	35	34	34	30	--	--	--
	8	779	1649	2803	21	64	63	60	57	50	48	37	32	33	44	38	38	37	37	33	21	--	--
10	973	2061	3503	33	68	66	64	61	53	52	41	36	37	46	40	40	39	39	35	24	--	--	
400	2	248	524	891	1	43	54	46	46	42	36	26	21	24	30	24	24	23	23	19	--	--	--
	4	495	1049	1783	5	54	58	52	51	45	40	31	26	28	37	31	31	30	30	26	--	--	--
	6	743	1573	2674	11	60	62	57	55	48	43	35	30	32	41	35	35	34	34	30	--	--	--
	8	990	2097	3565	20	65	65	61	58	52	46	39	34	36	44	38	37	37	37	33	21	--	--
10	1238	2621	4456	32	69	68	65	62	55	50	42	37	39	46	40	40	39	39	35	23	--	--	

1. Sound data is determined in a reverberation room at an independent sound laboratory, according to ISO 3741 and ISO 5135 standards.
2. L_w in dB/Oct. (re 1pW) are sound power levels for discharge sound and case radiated sound. Figures less than 17 dB are indicated by --.
3. The discharge sound pressure levels are determined with the assumptions as mentioned in table 1 for downstream ductwork including a diffuser with insulated plenum box.
4. The radiated sound pressure levels are determined with the assumptions as mentioned in table 1 for ceiling plenum and

5. L_p values are including a room absorption of 10 dB/Oct.
6. dB(A), NC and NR index figures are sound pressure levels. Figures less than 20 are indicated by --.
7. Δp_s is static pressure drop across VAV air volume control terminal with damper fully open.
8. For non standard applications and/or selections, please contact our technical staff.

Table 1: Assumptions for additional attenuation

Hz	125	250	500	1K	2K	4K
Discharge (dB)	5	10	20	30	30	25
Radiated (dB)	2	5	10	15	15	20

Type AFQ(G)OOB
AHQ(G)OOB

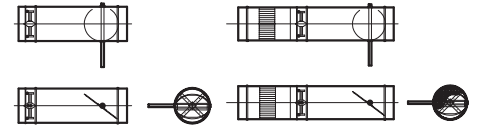

Sound data $\Delta p = 250$

Model	data referring to inlet spigot				min. Δp_s	$\Delta p = 250$ Pa																	
						discharge sound									radiated sound single wall								
	velocity	air volume				L_w in dB/Oct. (re 1pW)						Lp values			L_w in dB/Oct. (re 1pW)						Lp values		
						125 Hz	250 Hz	500 Hz	1000 Hz	2000 Hz	4000 Hz	dB(A)	NC	NR	125 Hz	250 Hz	500 Hz	1000 Hz	2000 Hz	4000 Hz	dB(A)	NC	NR
	m/s	l/s	CFM	m ³ /h		Pa	dB									dB							
100	2	15	31	53	2	45	48	45	43	40	29	21	--	--	26	23	26	27	30	28	--	--	--
	4	29	62	106	8	51	53	51	48	45	35	27	20	23	33	30	33	34	37	35	--	--	--
	6	44	94	160	17	55	57	54	52	49	40	31	25	27	37	34	37	38	41	39	21	--	--
	8	59	125	213	30	58	60	57	55	53	44	34	28	31	40	37	40	41	44	42	24	--	22
	10	74	156	266	47	60	63	60	57	56	47	36	32	33	42	39	42	43	46	44	26	22	24
125	2	23	49	84	2	43	47	46	43	40	33	20	--	--	35	31	31	28	30	24	--	--	--
	4	47	99	168	7	50	53	51	49	45	38	26	20	23	41	38	38	35	37	31	20	--	--
	6	70	149	253	16	54	57	55	53	48	41	30	25	27	45	42	42	39	41	35	24	--	--
	8	94	198	337	28	58	60	58	56	51	45	34	29	31	48	45	45	42	44	38	27	--	22
	10	117	248	421	44	61	63	61	58	54	48	37	32	34	50	47	47	44	46	40	29	22	24
160	2	39	82	139	2	42	47	46	44	43	40	20	--	--	35	31	31	28	30	24	--	--	--
	4	78	164	279	7	50	53	52	50	47	43	26	20	23	41	38	38	35	37	31	20	--	--
	6	116	246	418	15	55	57	55	54	50	46	31	24	27	45	42	42	39	41	35	24	--	--
	8	155	328	558	26	59	60	59	57	53	48	34	28	30	48	45	45	42	44	38	27	--	22
	10	194	410	697	41	62	63	61	59	55	50	37	32	33	50	47	47	44	46	40	29	22	24
200	2	61	129	219	2	43	38	41	39	36	30	--	--	--	36	31	31	29	30	24	--	--	--
	4	122	258	439	6	52	49	50	47	43	37	24	--	--	43	38	38	36	37	31	21	--	--
	6	183	387	658	14	57	55	56	51	47	42	30	22	24	47	42	42	40	41	35	25	--	--
	8	244	516	878	25	61	59	60	55	51	45	34	27	29	50	45	45	43	44	38	28	--	22
	10	305	645	1097	39	64	63	63	58	54	48	38	31	33	52	47	47	45	46	40	30	22	24
250	2	96	203	345	1	44	47	46	44	41	37	21	--	--	36	31	31	29	30	24	--	--	--
	4	192	406	690	6	53	55	54	50	46	42	29	23	25	43	38	38	36	37	31	21	--	--
	6	288	609	1035	13	59	60	59	54	50	46	34	28	31	47	42	42	40	41	35	25	--	--
	8	383	812	1380	23	63	64	62	57	53	48	38	33	35	50	45	45	43	44	38	28	--	22
	10	479	1015	1725	36	66	67	65	60	55	51	41	36	38	52	47	47	45	46	40	30	22	24
315	2	153	324	550	1	45	50	45	46	45	40	23	--	20	37	31	31	29	30	25	--	--	--
	4	306	648	1101	5	54	56	52	52	50	44	30	24	26	43	37	38	36	36	32	21	--	--
	6	459	971	1651	12	60	60	57	56	53	48	34	28	31	47	41	42	40	40	36	25	--	--
	8	612	1295	2202	22	65	64	61	59	56	51	38	33	34	50	44	44	43	43	39	27	--	21
	10	764	1619	2752	34	69	67	64	62	59	54	41	36	37	52	46	47	45	45	41	30	21	23
355	2	195	412	701	1	45	57	50	51	47	47	29	24	27	37	31	31	30	30	26	--	--	--
	4	389	824	1401	5	55	61	56	55	50	49	33	29	31	44	38	38	37	37	33	21	--	--
	6	584	1236	2102	12	61	64	60	58	52	51	37	32	34	48	42	42	41	41	37	25	--	--
	8	779	1649	2803	21	66	66	63	61	55	54	40	35	37	50	45	45	44	44	40	28	--	22
	10	973	2061	3503	33	70	69	66	64	57	56	43	38	39	53	47	47	46	46	42	30	22	24
400	2	248	524	891	1	46	59	51	52	49	45	31	27	29	37	31	30	30	30	26	--	--	--
	4	495	1049	1783	5	56	63	57	56	52	47	35	31	33	44	37	37	37	36	33	21	--	--
	6	743	1573	2674	11	62	66	61	59	54	49	39	35	36	48	41	41	41	40	37	25	--	--
	8	990	2097	3565	20	67	68	64	62	57	52	42	38	39	50	44	44	43	43	39	27	--	21
	10	1238	2621	4456	32	71	71	67	65	59	54	45	41	42	53	46	46	46	45	42	30	21	23

1. Sound data is determined in a reverberation room at an independent sound laboratory, according to ISO 3741 and ISO 5135 standards.
2. L_w in dB/Oct. (re 1pW) are sound power levels for discharge sound and case radiated sound. Figures less than 17 dB are indicated by --.
3. The discharge sound pressure levels are determined with the assumptions as mentioned in table 1 for downstream ductwork including a diffuser with insulated plenum box.
4. The radiated sound pressure levels are determined with the assumptions as mentioned in table 1 for ceiling plenum and

- suspended ceiling absorption.
5. Lp values are including a room absorption of 10 dB/Oct.
6. dB(A), NC and NR index figures are sound pressure levels. Figures less than 20 are indicated by --.
7. Δp_s is static pressure drop across VAV air volume control terminal with damper fully open.
8. For non standard applications and/or selections, please contact our technical staff.

Table 1: Assumptions for additional attenuation

Hz	125	250	500	1K	2K	4K
Discharge (dB)	5	10	20	30	30	25
Radiated (dB)	2	5	10	15	15	20

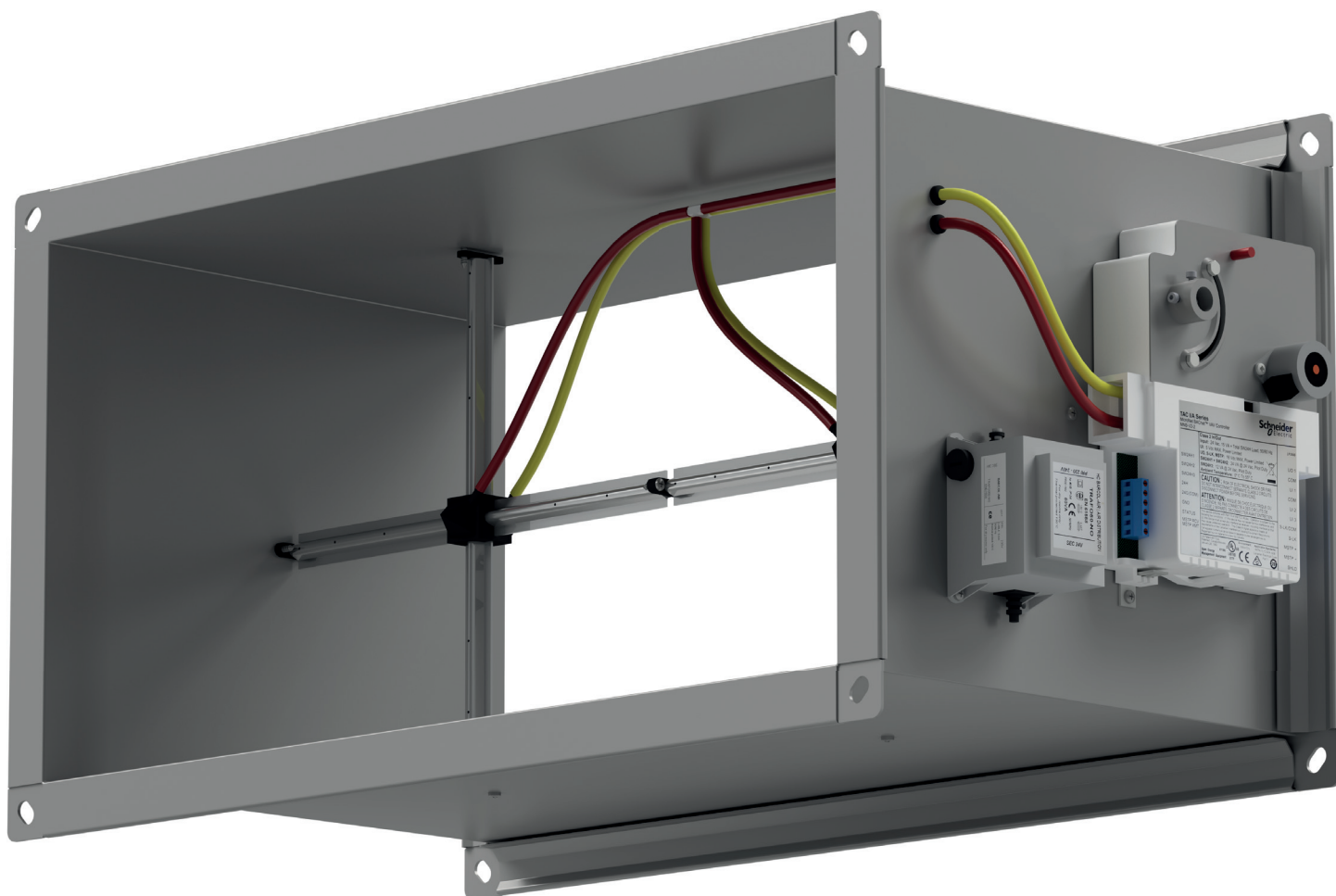

Type AERGOOB

Composition type designation:

A - F - S - G - O - O - B

Ordering example:

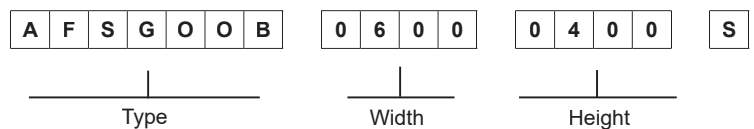

A Position 1: **Product Group**

A = accessoires

E Position 2: **Function**

- O = not applicable
- E = air volume measuring station
- F = air volume measuring and control station
- H = air volume measuring and pressure control station
- 1 = non standard, specify separately

P Position 3: **Controls (manufacturer)**

- O = not applicable
- R = rectangular air volume measuring station
- S = rectangular measuring and control station
- 1 = non standard. specify separately

O Position 4: **Outlet**

- O = not applicable
- D = double wall
- G = honeycomb air straightener
- F = double wall and honeycomb air straightener (price on request)
- 1 = non standard, specify separately

O Position 5: **Controls (manufacturer)**

- O = not applicable

O Position 6: **Controls (type & function)**

- O = without controls
- For controls, contact our sales staff

B Position 7: **Sensor**

- O = not applicable
- B = Flo-Cross® 2 x 12 point averaging and signal amplifying air flow sensor (standard)
- D = Flo-Cross® and static pressure sensor
- L = fully shut-off version
- 1 = non standard, specify separately

Ordering information:

Standard terminals:

- quantity of terminals
- complete 7 digit code
- terminal size or model
- air volume setting (Vmax, Vmin etc)
- control handing (standard right side)
- supply or return air

Non standard terminals:

- for non standard terminals a full description and/or drawing are requested

Type AER...B / AFS...B / AHS...B

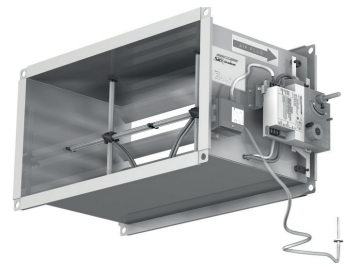
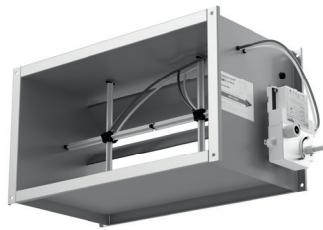

Application

The type AER...B rectangular air flow measuring station is designed for the accurate measurement of air flow in air duct systems courtesy of the patented air flow sensor type Flo-Cross®. This accurate signal can be read manually through a pressure-gauge or can be relayed to any building management system to be used to control such functions as: energy management, balancing supply and return air volumes, monitoring and controlling minimum fresh air volumes, tenancy billing by floor or by zone, to provide a reliable accurate reference point for air flow commissioning in VAV systems, etc.

The type AFS...B rectangular air flow measuring and air flow control station not only measures (like type AER...B), it also controls the air flow in air duct systems. These stations are designed to be used for optimum floor/zone balancing purposes by controlling return air flow in accordance to a measured supply air flow.

The type AHS...D rectangular air flow measuring and pressure control station is designed to control the supply duct pressure per zone, to a minimum value that still allows the VAV terminals in this zone to function efficiently, reducing operating cost and noise level.

Features for type AER, AFS and AHS:

- Flo-Cross®, high accuracy, centre-averaging air flow sensor.
- Static measuring device with 100% repeatability on-site measurements.
- Amplified signal, at least 2,5 times, to improve reading accuracy at low air velocity.
- The large number of test points (at least 24) and their positioning according to the "Tchebycheff rule" ensures a true average measurement signal.
- Better than 2,5% accuracy even with irregular duct approach.
- Required minimum straight ductwork approach of 1x diameter only.
- Compact design.
- Suitable for large air volumes.
- Low pressure loss over the terminal.
- Low noise production.
- Maintenance free.

Additional features for type AFS and AHS:

- Multi-leaf damper blade; full shut-off optional.

Technical information

Casing:

- Single wall, air-tight construction made of galvanized sheet steel; casing leakage rate to Class II VDI 3803 / DIN 24 194.
- 30 mm flange connections at the in- and outlet.
- With turbulent oncoming air flow an air straightener type A..G... is recommended (free area 98%, aluminium construction).

Flo-Cross®:

- Extruded aluminium construction with nylon core + feet.
- Twin test tubes: polyurethane flexible tubes, internal $\varnothing 4$ mm external $\varnothing 6$ mm, red high pressure, yellow low pressure.

Damper

- Multi-leaf damper, blade coupling system with aluminium gears.
- The blades are made of torsion proof hollow profiles with height of 100mm or 165mm.
- Damper blades are optionally provided with sealing lips for shut-off function. According NEN-EN-1751 class 2. Optional available is sealing according NEN-EN-1751 class 4.
- Damper shaft is made of $\varnothing 12$ mm solid steel and rotating in self lubricating polyamide maintenance free bearings.
- The casing and blades can be optionally supplied in stainless steel type 304 or type 316. Also powder-coated colour according to RAL is optionally available. When a stainless steel or RAL option is selected the Flo-Cross® will maintain standard made out of extruded aluminium with nylon core and feet.
- Recommended damper torques:
For surfaces ≤ 1 m²: 5 Nm.
For surfaces 1 – 2 m²: min. 8 Nm.
For surfaces ≥ 2 m²: min. 15 Nm.

Flo-Cross®:

- Extruded aluminium construction with nylon* core + feet. (* type Bergamid® B70 G30 H BK713-PA6-F30).

Static pressure sensor (applicable for control station type AHS):

- Aluminium construction complete with mounting bracket, to be fitted by others in the duct system.

Controls:

Suitable for use with pneumatic, analogue electronic or DDC controllers. Controls can be factory fitted, wired and calibrated. Controls enclosure (galvanized sheet steel) can be provided optionally.

Delivery format

Delivery format:

- Controls location are as a standard fitted on the right hand side of the terminal when looking in the direction of the air flow.
- On request, the terminal can be delivered with connections on the left hand side.
- When terminals are ordered with controls, these will be factory fitted, wired and calibrated upon request.
- When terminals are ordered with 'free-issue' controls by others, wiring diagrams and mounting instructions must be provided.

Type AER...B / AFS...B / AHS...B

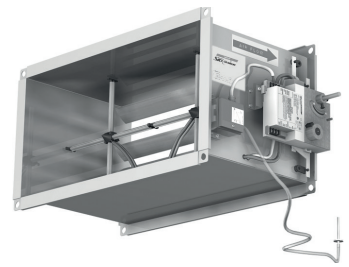
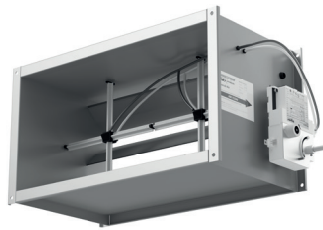

Specify as:

Example:

Supply and install rectangular air flow measuring and pressure control stations constructed from galvanized sheet steel. The casing leakage rate shall be classified according to class II, VDI 3803/DIN 24 194 and the inlet and outlet shall be provided with 30 mm flange connections. The measuring and control station shall have a multi-leaf opposed blade damper with steel damper shaft rotating in self lubricating Nylon bearings. A centre averaging air flow sensor with at least 2 x 12 test points and amplified signal air flow sensor, type Flo-Cross® shall control the air flow with an accuracy not less than 2.5%.

The controller shall be I/A Series, DDC controller:
LonMark® compatible, type MNL-V2RVx or
BACnet® compatible, type MNB-V2 (1 for air flow measuring and 1 for pressure control).

Controls must be factory fitted, wired and calibrated according to the following requirements.

Maximum air volume 1280 l/s.
Minimum air volume 512 l/s.
Static pressure setting 100 Pa.
Terminal size 400 x 400 mm.
Max. pressure loss 38 Pa.
Max. discharge sound index < NC20 (@250Pa Δp).
Max. radiated sound index < NC20 (@250Pa Δp).

Ordering example : type – model – handing = AHS000D – 0400 - 0400

Manufacturer: Barcol-Air, the Netherlands

Installation instructions:

The Barcol-Air “Air-Trac®” terminals shall be installed using at least two support brackets (DIN-rail or L-profile), with anti-vibration rubber under the terminal. Each of these brackets shall be fixed with two threaded rods to the ceiling slab above.

This installation method:

- 1 Shall prevent the body of the “Air-Trac®” terminal from high mechanical tension, which could damage the construction and performance of the terminal.
- 2 Shall prevent torsion on the “Air-Trac®” terminals, which could cause malfunction of the damper blades.
- 3 Provides some flexibility to the final location of the “Air-Trac®” terminals.

- 4 Use at least 1x diagonal straight duct length before the “Air-Trac®” inlet.
- 5 Additional manual volume control dampers (VDC’s) before the inlet are not required / recommended!!
6. All connections shall be thermally isolated.
7. Pressure sensing tubes of Flo-Cross® air flow sensor shall not be “kinked” or otherwise obstructed by the external duct insulation.

Optional 4 x Mupro fixing hooks can be used (see drawing).

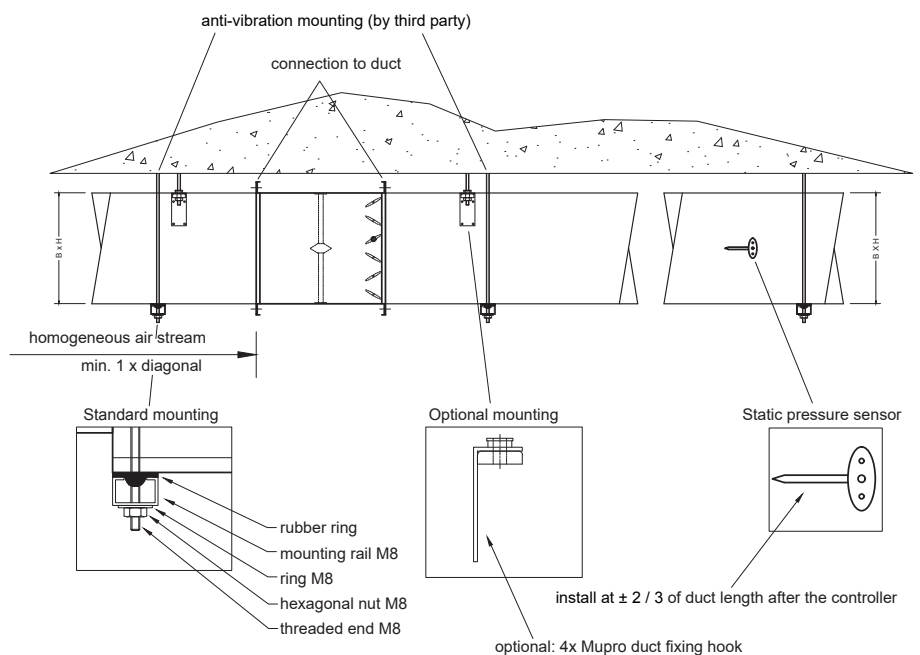

Mounting drawing type AFS...B

Type AER... B / AFS... B / AHS... B

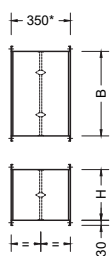
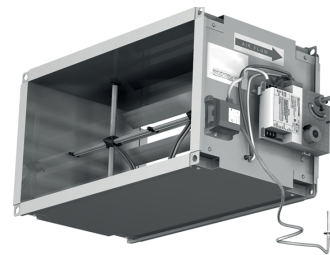
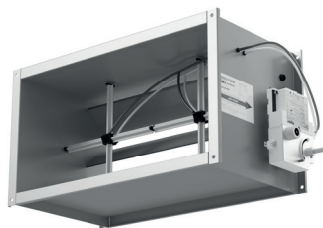

Type AER000B

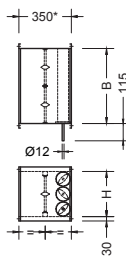

Type AFS000B

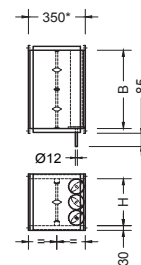

Type AHS000B

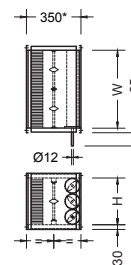

Type AHS000B

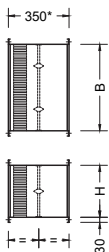

Type AER000B

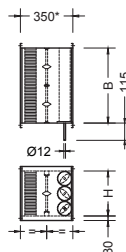

Type AFS000B

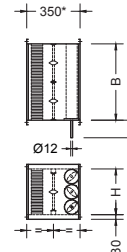

Type AHS000B

Dimension Height (H)	Width (W)																		
	200	250	300	350	400	450	500	550	600	700	750	800	900	1000	1200	1400	1600	1800	2000
100	*	*	*	*	*	*	*	*	*	*	*	*	*	*	*	*	*	*	*
200	*	*	*	*	*	*	*	*	*	*	*	*	*	*	*	*	*	*	*
250		*	*	*	*	*	*	*	*	*	*	*	*	*	*	*	*	*	*
300			*	*	*	*	*	*	*	*	*	*	*	*	*	*	*	*	*
350				*	*	*	*	*	*	*	*	*	*	*	*	*	*	*	*
400					*	*	*	*	*	*	*	*	*	*	*	*	*	*	*
450						*	*	*	*	*	*	*	*	*	*	*	*	*	*
500							*	*	*	*	*	*	*	*	*	*	*	*	*
600								*	*	*	*	*	*	*	*	*	*	*	*
700									*	*	*	*	*	*	*	*	*	*	*
800										*	*	*	*	*	*	*	*	*	*
900											*	*	*	*	*	*	*	*	*
1000												*	*	*	*	*	*	*	*
1100													*	*	*	*	*	*	*
1200														*	*	*	*	*	*

- Notes:
- All dimensions are in mm.
 - Other dimensions available upon request
 - * = Installed length
 - Higher or wider units available upon request
 - For hot water reheat sections for duct mounting see our separate NJOG/H documentation.

Kv values

Kv values rectangular VAV terminals (NK/NL/AFS/AHS)

Height (H)	Width (W)																		
	200	250	300	350	400	450	500	550	600	700	750	800	900	1000	1200	1400	1600	1800	2000
100	18	23	26	32	35														
200	35	45	56	63	71	81	91	101	106	126	136	142	162						
250		45	56	63	71	81	91	101	106	126	136	142	162	177					
300			73	87	101	115	123	137	147	175	189	203	220	248	294				
350				87	101	115	123	137	147	175	189	203	220	248	294	386			
400					128	146	165	183	202	238	249	255	292	329	383	386	436		
450						146	165	183	202	238	249	255	292	329	383	386	436	485	
500							211	235	258	291	318	328	376	423	516	580	673	706	801
600									290	346	373	401	459	515	601	580	673	706	801
700										408	426	458	542	587	687	794	864	961	1039
800												506	580	653	760	938	1049	1143	1294
900													663	747	915	938	1049	1143	1294
1000														839	1026	1153	1338	1402	1590
1100															1087	1153	1338	1402	1590
1200															1136	1367	1582	1660	1884

Kv values rectangular air flow measuring stations (AER)

Height (H)	Width (W)																		
	200	250	300	350	400	450	500	550	600	700	750	800	900	1000	1200	1400	1600	1800	2000
100	16	22	25	30	33														
200	34	44	54	61	68	78	88	98	103	122	132	137	156						
250		49	60	72	88	100	98	109	121	143	146	158	181	195					
300			72	85	99	113	121	134	143	171	185	198	215	243	287				
350				101	117	138	143	160	171	202	218	234	256	287	351	404			
400					126	144	162	180	198	234	245	251	287	324	377	449	502		
450						164	185	206	227	269	279	287	329	371	454	514	598	658	
500							208	232	255	287	314	324	371	417	510	579	672	741	834
600									287	342	369	397	454	510	595	709	793	908	1019
700										404	436	468	537	574	702	808	914	1075	1148
800												502	575	648	753	899	1004	1150	1255
900													658	741	908	1029	1195	1316	1483
1000														834	1019	1158	1343	1483	1668
1100															1081	1288	1492	1649	1853
1200															1130	1418	1506	1816	2038

Example

To determine the air flow for a terminal size 450 x 450 with a pressure differential signal (Δp_{fc}) of 30 Pa, you can use the following formula:

Arithmetical determination.

The given Kv value (164) must be used in the following formula:

$$V = Kv \sqrt{\Delta p_{fc}} = 164 \times \sqrt{30} = 898 \text{ l/s}$$

Zeta values

To be determined the static pressure loss for a rectangular air flow measuring station at a velocity of 8 m/s.

The average Zeta value of these air flow stations is approximately 0,40.

The given Zeta value must be used in the following formula:

$$p_s = \text{Zeta} \times 0.5 \times \text{Rho} \times v^2 = 0.40 \times 0.5 \times 1.2 \times 8^2 = 13 \text{ Pa}$$

* Rho = Specific density ($\approx 1.2 \text{ kg/m}^3$ at 20°C and 50% rel. humidity)

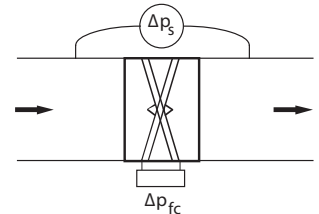

Weight AFS units (excl. controls and enclosure)

Height (H)	Width (W)																		
	200	250	300	350	400	450	500	550	600	700	750	800	900	1000	1200	1400	1600	1800	2000
100	8	9	9	9	9														
200	9	9	10	10	11	11	12	12	13	14	14	14							
250		10	10	11	11	12	12	13	13	15	15	16	17	18					
300			11	11	12	13	13	14	14	16	16	17	18	19	22				
350				12	12	13	14	15	15	17	17	18	20	21	24	27			
400					13	14	15	15	16	18	19	19	21	22	26	29	32		
450						15	15	16	17	19	20	21	22	24	27	31	34	38	
500							16	17	18	20	21	22	24	26	29	33	37	41	44
600									20	22	23	24	26	29	33	37	42	46	50
700										24	25	27	29	32	37	42	47	52	57
800												29	32	35	40	46	52	57	63
900													35	38	44	50	57	63	69
1000														41	48	55	61	68	75
1100															51	59	66	74	81
1200															55	63	71	79	87

Weight AHS units (excl. controls and enclosure)

Height (H)	Width (W)																		
	200	250	300	350	400	450	500	550	600	700	750	800	900	1000	1200	1400	1600	1800	2000
100	11	11	12	12	13														
200	12	12	13	14	15	15	16	17	18	19	20	21							
250		13	14	15	16	16	17	18	19	20	21	22	24	25					
300			15	16	16	17	18	19	20	22	23	24	25	27	31				
350				16	17	18	19	20	21	23	24	25	27	29	33	37			
400					18	19	20	21	22	24	25	27	29	31	35	39	43		
450						20	21	22	24	26	27	28	30	33	37	42	46	51	
500							22	23	25	27	28	30	32	34	39	44	49	54	58
600									27	30	31	33	35	38	43	49	54	60	65
700										32	34	35	39	42	48	54	60	66	72
800												38	42	45	52	59	65	72	79
900													45	49	56	63	71	78	85
1000														52	60	68	76	84	92
1100															64	73	82	90	99
1200															69	78	87	96	105

Dimensions in mm.

Type AFS(G)OOB
AHS(G)OOB

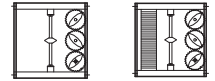

Sound data $\Delta p = 125 \text{ Pa}$

Size (W x H)	data referring to inlet spigot				min. Δp_s	$\Delta p = 125 \text{ Pa}$																	
						discharge sound						radiated sound single wall											
	velocity		air volume			L_w in dB/Oct. (re 1pW)						Lp values			L_w in dB/Oct. (re 1pW)						Lp values		
						125 Hz	250 Hz	500 Hz	1000 Hz	2000 Hz	4000 Hz	dB(A)	NC	NR	125 Hz	250 Hz	500 Hz	1000 Hz	2000 Hz	4000 Hz	dB(A)	NC	NR
m/s	l/s	CFM	m ³ /h	Pa	dB						dB												
350 x 300 (DN 355)	2	210	445	756	1	47	48	43	27	30	22	21	--	--	33	32	26	-	-	-	--	--	--
	4	420	889	1512	6	57	60	56	45	44	37	33	28	30	43	44	39	31	28	29	23	--	--
	6	630	1334	2268	13	59	62	58	49	48	41	35	31	33	45	46	41	35	32	33	25	--	21
	8	840	1779	3024	23	58	61	55	47	47	41	33	29	31	44	45	38	33	31	33	23	--	--
	10	1050	2224	3780	35	60	60	54	47	49	42	34	29	31	46	44	37	33	33	34	23	--	--
350 x 350 (DN 400)	2	245	519	882	1	48	48	43	28	30	23	22	--	--	34	32	26	-	-	-	--	--	--
	4	490	1038	1764	6	58	61	57	46	45	38	34	29	31	44	45	40	32	29	30	23	--	--
	6	735	1556	2646	13	60	63	59	49	48	42	36	31	33	46	47	42	35	32	34	25	--	21
	8	980	2075	3528	23	58	61	56	48	47	41	34	30	32	44	45	39	34	31	33	24	--	--
	10	1225	2594	4410	35	61	61	55	48	50	43	34	29	31	47	45	38	34	34	35	24	--	--
400 x 400 (DN 450)	2	320	678	1152	1	49	50	44	29	31	24	23	--	--	35	34	27	-	-	-	--	--	--
	4	640	1355	2304	6	59	62	58	47	46	39	35	30	32	45	46	41	33	30	31	25	--	20
	6	960	2033	3456	13	61	64	60	51	50	43	37	33	35	47	48	43	37	34	35	27	--	23
	8	1280	2711	4608	23	60	63	57	49	49	43	35	31	33	46	47	40	35	33	35	25	--	21
	10	1600	3388	5760	35	62	62	56	49	51	44	36	31	33	48	46	39	35	35	36	25	--	21
500 x 400 (DN 500) (L _{pA(0,2)})	2	400	847	1440	1	49	50	45	30	32	25	23	--	--	35	34	28	-	-	-	--	--	--
	4	800	1694	2880	6	59	62	59	48	47	40	35	30	32	45	46	42	34	31	32	25	--	20
	6	1200	2541	4320	13	61	64	60	52	50	44	37	33	35	47	48	43	38	34	36	27	--	23
	8	1600	3388	5760	23	60	63	57	50	50	44	35	31	33	46	47	40	36	34	36	25	--	21
	10	2000	4235	7200	35	62	62	57	50	52	45	36	31	33	48	46	40	36	36	37	25	--	21
600 x 400 (DN 560)	2	480	1016	1728	1	49	50	45	31	33	26	23	--	--	35	34	28	-	17	17	--	--	--
	4	960	2033	3456	6	59	62	59	49	48	41	35	30	32	45	46	42	35	32	33	25	--	20
	6	1440	3049	5184	13	61	64	60	52	51	45	37	33	35	47	48	43	38	35	37	27	--	23
	8	1920	4066	6912	23	60	63	58	51	50	44	35	31	33	46	47	41	37	34	36	25	--	21
	10	2400	5082	8640	35	62	62	57	51	53	46	36	31	33	48	46	40	37	37	38	26	--	21
800 x 400 (DN 630)	2	640	1355	2304	1	49	50	46	32	34	27	23	--	--	35	34	29	18	18	19	--	--	--
	4	1280	2711	4608	6	59	62	59	50	49	42	35	30	32	45	46	42	36	33	34	25	--	20
	6	1920	4066	6912	13	61	64	61	54	53	46	37	33	35	47	48	44	40	37	38	27	--	23
	8	2560	5421	9216	23	60	63	58	52	52	46	35	31	33	46	47	41	38	36	38	25	--	21
	10	3200	6776	11520	35	62	62	57	52	54	47	36	31	33	48	46	40	38	38	39	26	--	21
900 x 450 (DN 710)	2	810	1715	2916	1	49	50	46	33	35	28	23	--	--	35	34	29	19	19	20	--	--	--
	4	1620	3431	5832	6	59	62	60	51	50	43	35	30	32	45	46	43	37	34	35	25	--	20
	6	2430	5146	8748	13	61	64	61	55	54	47	37	33	35	47	48	44	41	38	39	27	--	23
	8	3240	6861	11664	23	60	63	59	53	53	47	35	31	33	46	47	42	39	37	39	26	--	21
	10	4050	8576	14580	35	62	62	58	53	55	48	36	31	33	48	46	41	39	39	40	26	--	21

1. Sound data is determined in a reverberation room at an independent sound laboratory, according to ISO 3741 and ISO 5135 standards.
2. L_w in dB/Oct. (re 1pW) are sound power levels for discharge sound and case radiated sound. Figures less than 17 dB are indicated by "--".
3. The discharge sound pressure levels are determined with the assumptions as referred to in table 1 for downstream ductwork including a diffuser with insulated plenum box.

4. The radiated sound pressure levels are determined with the assumptions as referred to in table 1 for ceiling plenum and suspended ceiling absorption.
5. Lp values are including a room absorption of 10 dB/Oct.
6. dB(A), NC and NR index figures are sound pressure levels. Figures less than 20 are indicated by "--".
7. Δp_s is static pressure drop across VAV air volume control terminal with damper fully open.

8. For non standard applications and/or selections, please contact our technical staff.

Table 1: Assumptions for additional attenuation

Hz	125	250	500	1000	2000	4000
Discharge (dB)	5	10	20	30	30	25
Radiated (dB)	2	5	10	15	15	20

Table 2: Correction table for other unit sizes: $L_{pA}' = L_{pA(0,2)} + \Delta L_{pA}$

WxH (m ²)	0,03	0,04	0,05	0,06	0,07	0,08	0,10	0,12	0,14	0,16	0,18	0,20	0,25	0,30	0,40	0,50	0,60
ΔL_{pA} (dB)	-7	-6	-5	-4	-4	-3	-2	-1	-1	-1	0	0	0	1	1	1	2

Type AFS(G)OOB
AHS(G)OOB

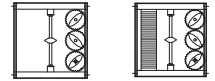

Sound data Δ p = 250 Pa

Size (W x H)	data referring to inlet spigot				min. Δ p _s	Δ p = 250 Pa																	
						discharge sound						radiated sound single wall											
	velocity		air volume			L _w in dB/Oct. (re 1pW)						L _p values			L _w in dB/Oct. (re 1pW)						L _p values		
						125 Hz	250 Hz	500 Hz	1000 Hz	2000 Hz	4000 Hz	dB(A)	NC	NR	125 Hz	250 Hz	500 Hz	1000 Hz	2000 Hz	4000 Hz	dB(A)	NC	NR
m/s	l/s	CFM	m ³ /h	Pa	dB						dB												
350 x 300 (DN 355)	2	210	445	756	1	49	50	46	31	32	25	24	--	--	35	34	29	-	-	-	--	--	--
	4	420	889	1512	6	59	62	59	49	47	39	35	31	33	45	46	42	35	31	31	25	--	21
	6	630	1334	2268	13	66	70	68	60	56	49	43	40	41	52	54	51	46	40	41	33	27	29
	8	840	1779	3024	23	67	71	69	62	58	51	44	41	42	53	55	52	48	42	43	34	28	31
	10	1050	2224	3780	35	66	70	67	61	58	51	43	40	41	52	54	50	47	42	43	33	27	29
350 x 350 (DN 400)	2	245	519	882	1	50	51	47	32	33	25	24	--	21	36	35	30	18	17	17	--	--	--
	4	490	1038	1764	6	60	63	60	49	48	40	36	32	33	46	47	43	35	32	32	26	--	22
	6	735	1556	2646	13	67	71	69	61	57	50	44	41	42	53	55	52	47	41	42	34	28	30
	8	980	2075	3528	23	68	72	70	63	59	52	45	42	43	54	56	53	49	43	44	35	29	31
	10	1225	2594	4410	35	67	71	68	61	58	52	44	41	42	53	55	51	47	42	44	34	28	30
400 x 400 (DN 450)	2	320	678	1152	1	51	52	48	33	34	26	25	--	22	37	36	31	19	18	18	--	--	--
	4	640	1355	2304	6	61	64	61	50	49	41	37	33	35	47	48	44	36	33	33	27	--	23
	6	960	2033	3456	13	68	72	70	62	58	51	45	42	43	54	56	53	48	42	43	35	29	31
	8	1280	2711	4608	23	69	73	71	64	60	53	46	44	44	55	57	54	50	44	45	36	31	33
	10	1600	3388	5760	35	68	72	69	63	59	53	45	42	43	54	56	52	49	43	45	35	29	31
500 x 400 (DN 500) (L _{pA(0,2)})	2	400	847	1440	1	51	52	48	34	35	27	25	--	22	37	36	31	20	19	19	--	--	--
	4	800	1694	2880	6	61	64	61	51	50	42	37	33	35	47	48	44	37	34	34	27	--	23
	6	1200	2541	4320	13	68	72	71	63	59	52	45	42	43	54	56	54	49	43	44	36	29	31
	8	1600	3388	5760	23	69	73	71	65	61	54	46	44	44	55	57	54	51	45	46	36	31	33
	10	2000	4235	7200	35	68	72	69	64	60	54	45	42	43	54	56	52	50	44	46	35	29	31
600 x 400 (DN 560)	2	480	1016	1728	1	51	52	49	35	36	28	25	--	22	37	36	32	21	20	20	--	--	--
	4	960	2033	3456	6	61	64	62	52	50	43	37	33	35	47	48	45	38	34	35	27	--	23
	6	1440	3049	5184	13	68	72	71	64	60	53	45	42	43	54	56	54	50	44	45	36	29	31
	8	1920	4066	6912	23	69	73	71	66	62	55	46	44	44	55	57	54	52	46	47	37	31	33
	10	2400	5082	8640	35	68	72	69	64	61	55	45	42	43	54	56	52	50	45	47	35	29	31
800 x 400 (DN 630)	2	640	1355	2304	1	51	52	49	36	37	29	26	--	22	37	36	32	22	21	21	--	--	--
	4	1280	2711	4608	6	61	64	62	53	52	44	37	33	35	47	48	45	39	36	36	28	--	23
	6	1920	4066	6912	13	68	72	71	65	61	54	45	42	43	54	56	54	51	45	46	36	29	31
	8	2560	5421	9216	23	69	73	72	67	63	56	46	44	44	55	57	55	53	47	48	37	31	33
	10	3200	6776	11520	35	68	72	70	66	62	56	45	42	43	54	56	53	52	46	48	36	29	31
900 x 450 (DN 710)	2	810	1715	2916	1	51	52	49	37	38	30	26	--	22	37	36	32	23	22	22	--	--	--
	4	1620	3431	5832	6	61	64	63	54	53	45	37	33	35	47	48	46	40	37	37	28	--	23
	6	2430	5146	8748	13	68	72	72	66	62	55	45	42	43	54	56	55	52	46	47	36	29	31
	8	3240	6861	11664	23	69	73	72	68	64	57	46	44	44	55	57	55	54	48	49	37	31	33
	10	4050	8576	14580	35	68	72	70	67	64	57	45	42	43	54	56	53	53	48	49	36	29	31

1. Sound data is determined in a reverberation room at an independent sound laboratory, according to ISO 3741 and ISO 5135 standards.
2. L_w in dB/Oct. (re 1pW) are sound power levels for discharge sound and case radiated sound. Figures less than 17 dB are indicated by "--".
3. The discharge sound pressure levels are determined with the assumptions as referred to in table 1 for downstream ductwork including a diffuser with insulated plenum box.

4. The radiated sound pressure levels are determined with the assumptions as referred to in table 1 for ceiling plenum and suspended ceiling absorption.
5. L_p values are including a room absorption of 10 dB/Oct.
6. dB(A), NC and NR index figures are sound pressure levels. Figures less than 20 are indicated by "--".
7. Δp_s is static pressure drop across VAV air volume control terminal with damper fully open.

8. For non standard applications and/or selections, please contact our technical staff.

Table 1: Assumptions for additional attenuation

Hz	125	250	500	1000	2000	4000
Discharge (dB)	5	10	20	30	30	25
Radiated (dB)	2	5	10	15	15	20

Table 2: Correction table for other unit sizes: L_{pA'} = L_{pA(0,2)} + Δ L_{pA}

WxH (m ²)	0,03	0,04	0,05	0,06	0,07	0,08	0,10	0,12	0,14	0,16	0,18	0,20	0,25	0,30	0,40	0,50	0,60
Δ L _{pA} (dB)	-7	-6	-5	-4	-4	-3	-2	-1	-1	-1	0	0	0	1	1	1	2



OUR TECHNOLOGY | YOUR WELLBEING

BARCOL-AIR | AIR DISTRIBUTION

Cantekoogweg 10-12 - 1442 LG Purmerend, The Netherlands

T +31 (0)299 689 300 | **E** export@barcol-air.nl

WWW.BARCOL-AIR.NL